



*Date: 26th of April, 2017*  
*Place: Aalborg, Denmark*

# Knowledge **FOR** Resilient so**CI**ety

**Project Meeting in Aalborg**

***UNIVERSITY OF NOVI SAD***



Co-funded by the  
Erasmus+ Programme  
of the European Union





# YOUR SPECIAL MOBILITY STRAND



Co-funded by the  
Erasmus+ Programme  
of the European Union



# Presentation outlines

- Special Mobility Strand(SMS): definition and eligible activities/participants
- Individual mobility scheme:
  - Preparation
  - Implementation
  - Follow-up
- Financial Management of SMS grant
- EACEA Mobility Tool



# Special Mobility Strand (SMS): what is it?

- ✓ Additional grant to the selected CBHE to support international mobility of student and staff.
- ✓ Mobility for studying, training and teaching purposes that must be instrumental to the objectives of the CBHE

## Who are beneficiaries of SMS within K-FORCE project?

### STUDENTS:

- Must be registered in a Higher Education Institution (HEI) involved in the selected CBHE Project.

### STAFF:

- HEI staff members are eligible to participate in the SMS mobility (teaching and training mobility).



# Special rules for STUDENTS

- ✓ Must be registered in a Higher Education Institution (HEI) involved in the selected CBHE Project.
- ✓ **Must be enrolled at least in the second year** of higher education studies (for study mobility)
- ✓ The same student may participate in mobility periods **totaling up to 12 months maximum per cycle of study**, independently of the number and type of mobility activities (during the first, second and third study cycle)
- ✓ **Important: Prior experience under E+Key Action1 - Credit Mobility, LLP-Erasmus Programme and the Erasmus Mundus Programme counts towards the 12 months per study cycle.**



# Special rules for STAFF

## Teaching Mobility:

- Sending HEI teaching staff to teach at a host beneficiary HEI.

## Training Mobility:

- Participation in structured courses, including professionally focused language trainings, or training events abroad (conferences excluded);
- Job shadowing/observation periods/trainings at a beneficiary HEI.

**min 8 hours per week**



# Main Phases of the SMS Scheme

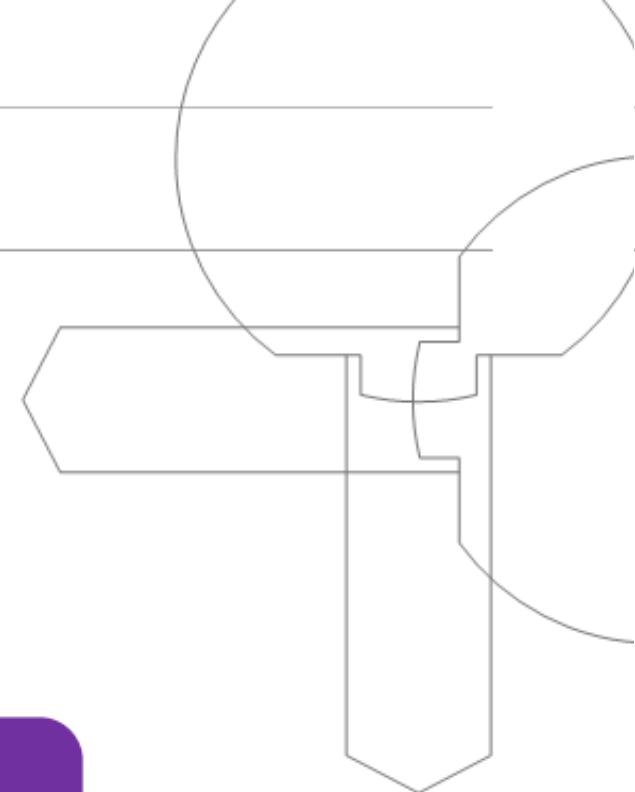
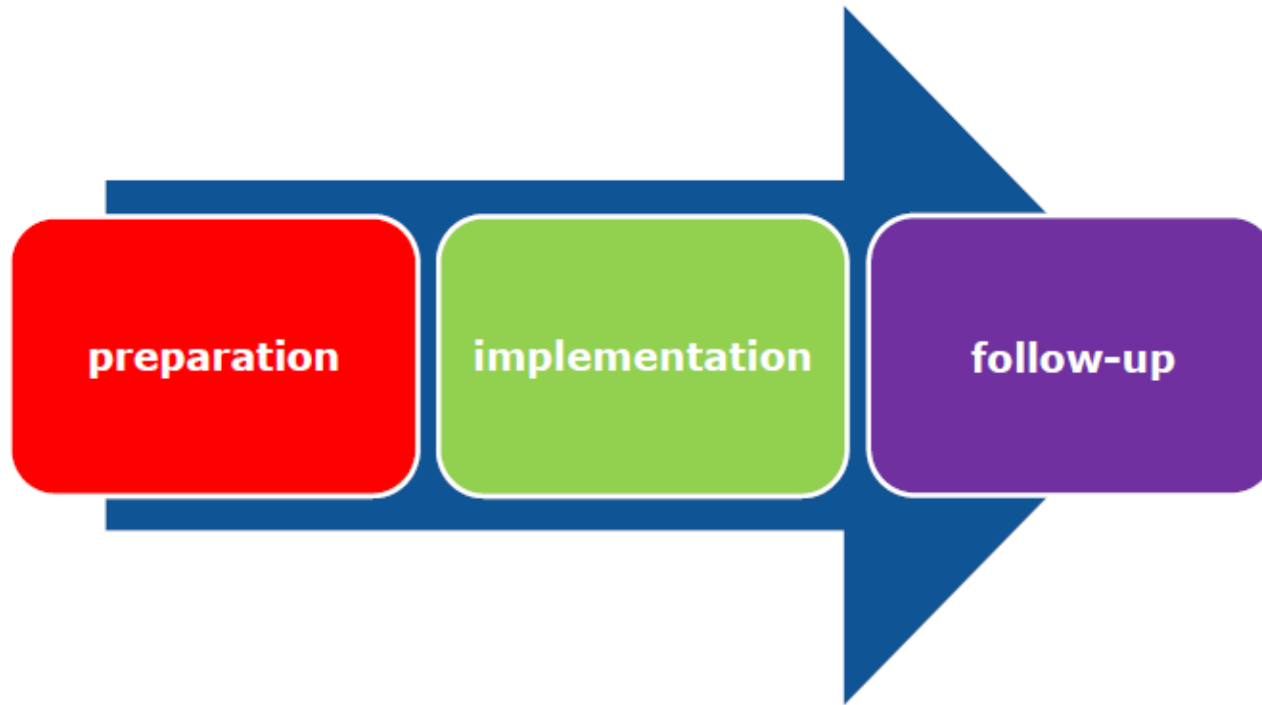

# Preparation: Basic Principles

- **SMS must be processed by International Relation Unit/Office at HEIs.**
  - Staff that regularly deal with KA1 within Erasmus+ framework must be fully included in realization of SMS.
- Abide by the principles of E+Charter
- Relevant information on selection process and admission and selection criteria must be available to candidates well in advance.

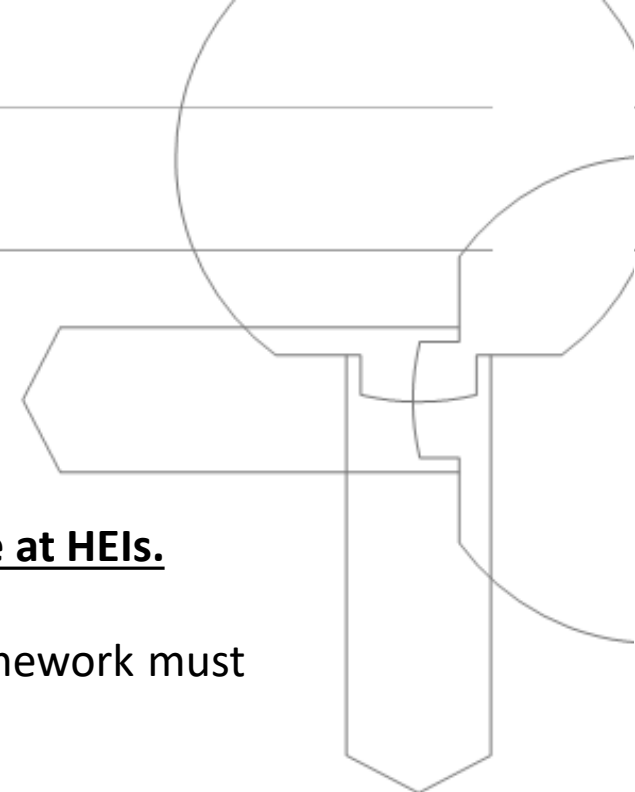



# Preparation: compulsory documents

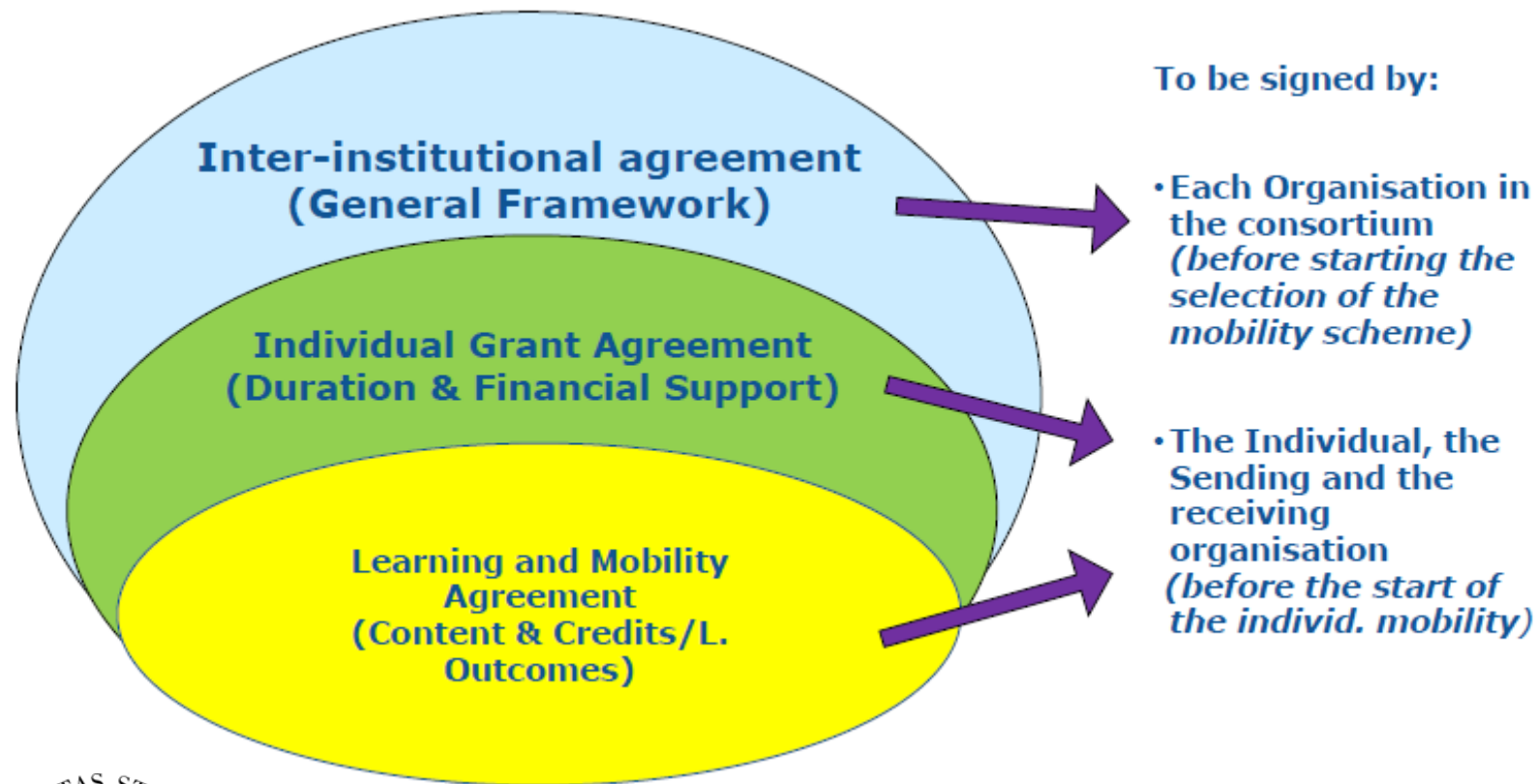

# Preparation: Inter-Institutional Agreement

- The same principle as in Erasmus+ KA 1
- Signed by each beneficiary's organisation before the selection of the mobility scheme (agreements will be bilateral).
- Provides specific provisions on the roles of the organisations, selection procedure, admission/selection criteria, appeal procedures, decision making process, quality assurance measures...

**Inter-institutional agreements will be prepared by UNS before DTU-LUND meeting and distributed to every partner participating in SMS.**  
**I-I agreement must be signed by the legal representative of the institution and delivered to UNS at the meeting.**



# Preparation: Inter-Institutional Agreement

## **Sending organization should:**

- Promote and raise awareness
- Select the candidates in line with I-I agreement
- Provide support in preparation of the individual mobility (visa, administrative question, insurance etc)

## **Receiving organization should:**

- Inform locally
- Prepare logistics and support for incoming individuals
- Welcome and monitor the activities

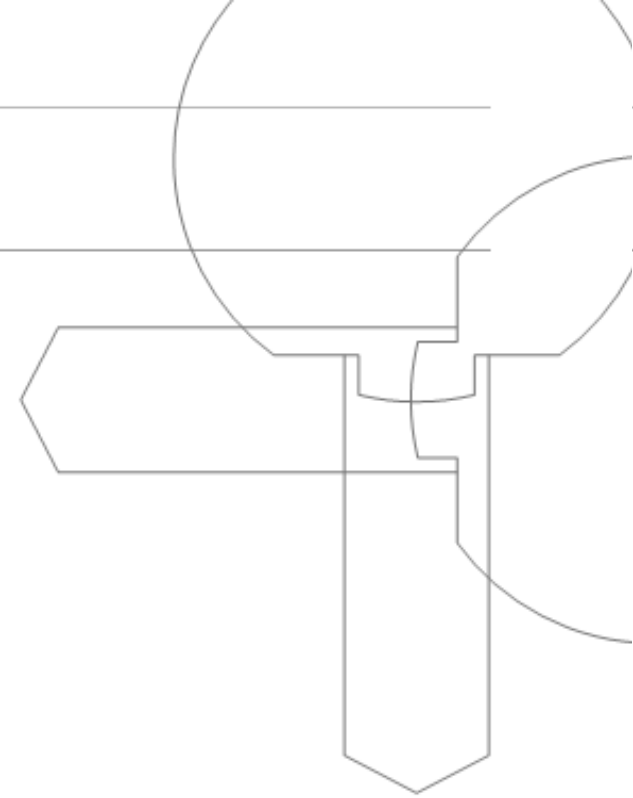

# Preparation: Individual Grant Agreement

- The same principle as in Erasmus+ KA 1

Individual grant agreement contains specific provisions related to:

- the duration of the scholarship,
- the financial support that the students will receive,
- the payment arrangements,
- the insurance requirements during the mobility
- participants' report
- other general conditions

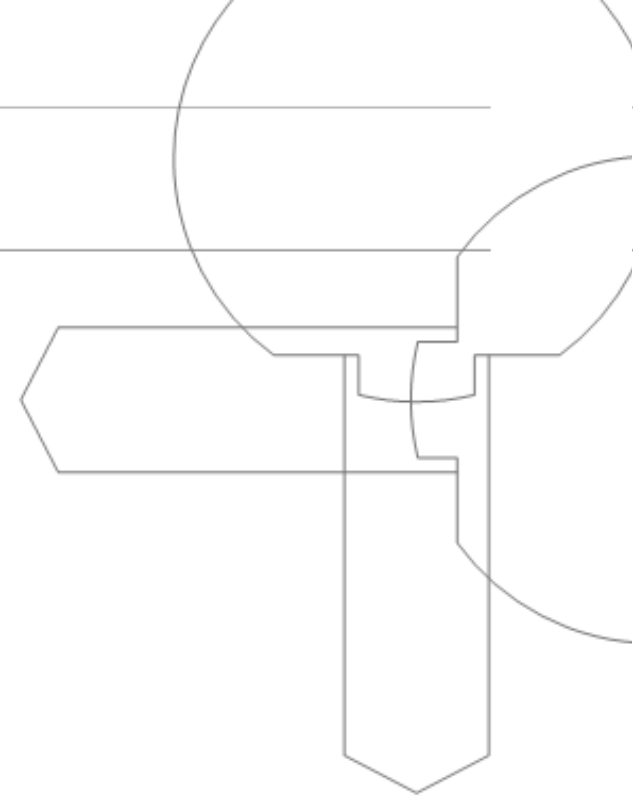

Co-funded by the  
Erasmus+ Programme  
of the European Union



# Preparation: Individual Grant Agreement



**Grant agreement +  
for students**

Learning Agreement for studies  
Learning Agreement for traineeship

**Grant agreement +  
for staff**

Mobility Agreement for teaching  
Mobility Agreement for training

# Preparation: Learning/Mobility Agreement

Grant agreement for students		Grant agreement for staff	
Learning Agreement for		Mobility Agreement for	
Studies	Traineeship	Teaching	Training
<ul style="list-style-type: none"> <li>• List of courses with ECTS (or equivalent)</li> <li>• targeted learning outcomes</li> <li>• formal recognition</li> </ul>	<ul style="list-style-type: none"> <li>• knowledge skills</li> <li>• competences expected to be acquired</li> <li>• (compulsory/<u>voluntary?any ECTS?</u>)</li> </ul>	<ul style="list-style-type: none"> <li>• overall objectives</li> <li>• activities and added value foreseen</li> <li>• expected outcomes and impact</li> </ul>	

**Learning Agreement and Mobility Agreement must be: agreed and signed by the individual, the sending and the receiving organisations BEFORE departure**

## Implementation: basic principles

- Pre-financing of the grant must be foreseen for students in order to facilitate the installation process.
- Receiving organisation and sending organisation have to ensure a constant follow-up and regular monitoring on the individual mobility.
- All mobility details must be encoded in the EACEA Mobility tool.

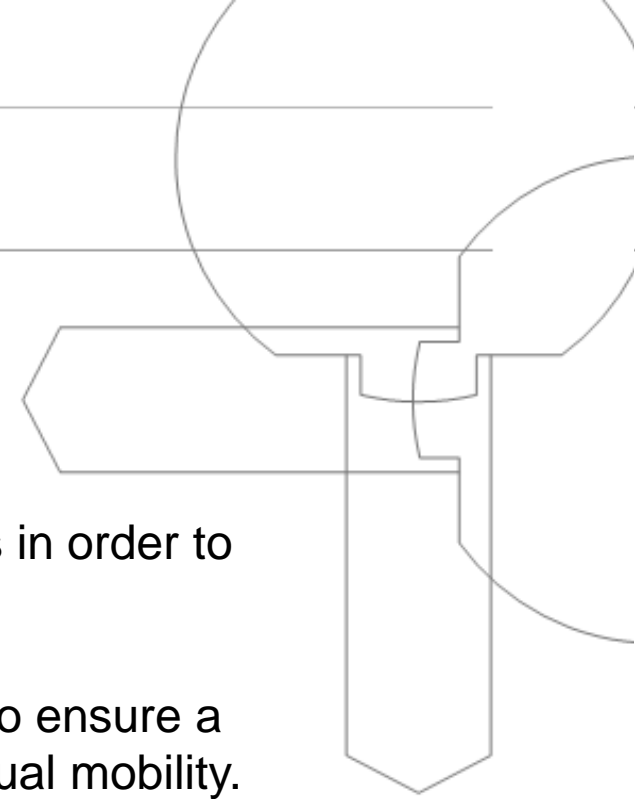

## Follow-up: basic principles

Beneficiary organisations involved in the SMS commit to:

- **Recognise the ECTS or equivalent credits obtained by the students during the activities carried out and agreed in the Learning Agreement**
- Avoid any extension of the study period upon return to take additional exams
- Recognise, disseminate and embed the learning outcomes of the staff mobility (for training purposes)
- **Solicit the individuals to fill in the Participant Report before the end of mobility (for students) and right after the end of the mobility (for staff).**





# Financial Management: basic principles

- The budgets of your CBHE and SMS must be kept separated
- It is a contribution to cover two types of costs (*based on the principle of unit costs*): **Subsistence costs and travel**
- Individuals cannot benefit at the same time from SMS support and E+ International Credit Mobility



# Financial Management: basic principles

## Subsistence costs for students

- Students selected must be exempted from paying fees for tuition, registration, examinations and access to laboratory and library facilities at the receiving institution.
- **The amount must be paid in full and directly to the student concerned.**
- Consortia are strongly recommended to manage their SMS grants in an account in euros.

## Subsistence costs for staff

Beneficiary organisation in accordance with their institutional practice can decide to either :

- **provide the amount directly to the staff members concerned** or
- provide the participant with direct provision of the required services (i.e. payment of the hotel, subsistence, local transportation, personal or optional health insurance).



# Financial Management: basic principles

## Travel Costs for Students and Staff

Distance Band	Amount per participant (return trip)
For travel distances between 100 and 499 KM	150 EUR
For travel distances between 500 and 1999 KM	275 EUR

Consortia can either provide:

- **directly to the participant the unit costs corresponding to the appropriate distance band** or
- provide the participant with travel support in the form of direct provision of the required travel support services.



Co-funded by the  
Erasmus+ Programme  
of the European Union



## Modification of the mobility scheme

Regardless of the duration, the minimum number of:

- ✓ students from Partner Countries and Programme Countries
- ✓ staff members from Partner Countries and Programme Countries

**As foreseen in the original proposals must be respected!**

These figures and the budget allocation for each categorie are indicated in the Estimated Budget of the Action.

Modification of the mobility scheme can take place provided that:

- ✓ it does not affect the minimum number of motilities foreseen,
- ✓ the change in the amount of the budget indicated in the GA for one or more of the mobility categories does not exceed 10 %, and
- ✓ the total estimated budget indicated in the GA is not exceeded.



# EACEA Mobility Tool

- Support to the coordinators in the management of the individual mobility
- Transcription of information on mobility tracks, activities, credits earned, amounts disbursed and automatic reports.
- **Coordinator must update the tool regularly**
  - To ease the management
  - For statistical analysis and quantitative assessments

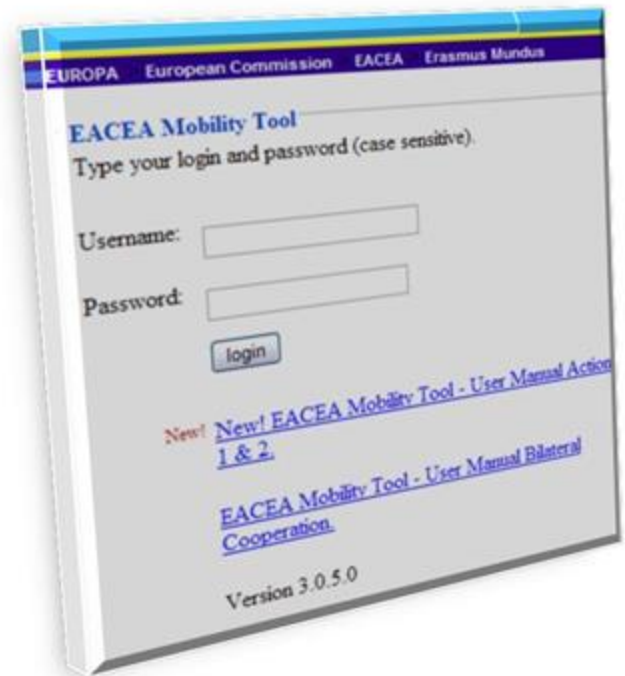

# K-FORCE SMS scheme for STAFF

receiving	UNS	UNTZ	UBL	UT	VTSNS	EPOKA	
sending							year
UNS		2 master	2 master			2 master	I II III
UNTZ	2 master					2 master	I II III
UBL	2 master					2 master	I II III
UT					4 master		I II III
VTSNS				4 master			I II III
EPOKA	2 master	2 master	2 master				I II III

- All mobilities are proposed for 5 months (in 2nd semester).
- Numbers represent numbers of visiting students.

# K-FORCE SMS scheme for STAFF

receiving	DTU	LU	AAU	UNIZA	UKIM	UNS	UNTZ	UBL	UT	VTSNS	EPOKA	
sending												year
DTU						1 teaching - m 1 teaching - m,d	1 teaching - m				1 teaching - m	I II III
LU						1 teaching - m		1 teaching - m	1 teaching - m	1 teaching - m		I II III
AAU						1 teaching - m 1 teaching - m,d	1 teaching - m	1 teaching - m	1 teaching - m	1 teaching - m	1 teaching - m	I II III
UNIZA						1 teaching - m 1 teaching - m,d	1 teaching - m	1 teaching - m	1 teaching - m	1 teaching - m	1 teaching - m	I II III
UKIM						1 teaching - m 1 teaching - m,d	1 teaching - m	1 teaching - m	1 teaching - m	1 teaching - m	1 teaching - m	I II III
UNS	1 training 1 training	1 training		1 training 1 training	1 training 1 training		1 teaching - m	1 teaching - m	1 teaching - m		1 teaching - m	I II III
UNTZ		1 training	1 training 1 training	1 training 1 training	1 training 1 training	1 teaching - m 1 teaching - m,d			1 teaching - m	1 teaching - m	1 teaching - m	I II III
UBL	1 training		1 training 1 training	1 training 1 training	1 training 1 training	1 teaching - m 1 teaching - m,d			1 teaching - m	1 teaching - m	1 teaching - m	I II III
UT	1 training		1 training 1 training	1 training 1 training	1 training 1 training	1 teaching - m 1 teaching - m,d	1 teaching - m	1 teaching - m		1 teaching - m		I II III
VTSNS	1 training		1 training 1 training	1 training 1 training	1 training 1 training		1 teaching - m	1 teaching - m	1 teaching - m		1 teaching - m	I II III
EPOKA		1 training	1 training 1 training	1 training 1 training	1 training 1 training	1 teaching - m 1 teaching - m,d	1 teaching - m	1 teaching - m		1 teaching - m		I II III



Co-funded by the  
Erasmus+ Programme  
of the European Union



Thank you  
for your attention  
*Contact info about the presenter:*

**Knowledge FOR Resilient soCiEty**